

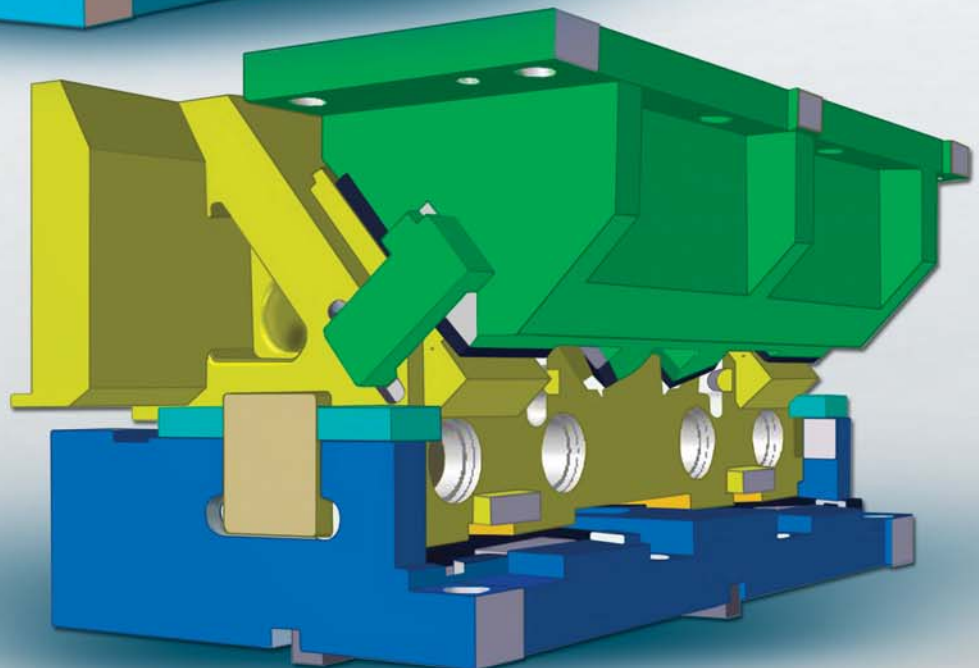

TRUSTED SOLUTIONS AND INNOVATION

AERIAL & DIE MOUNT WIDE CAMS CATALOG

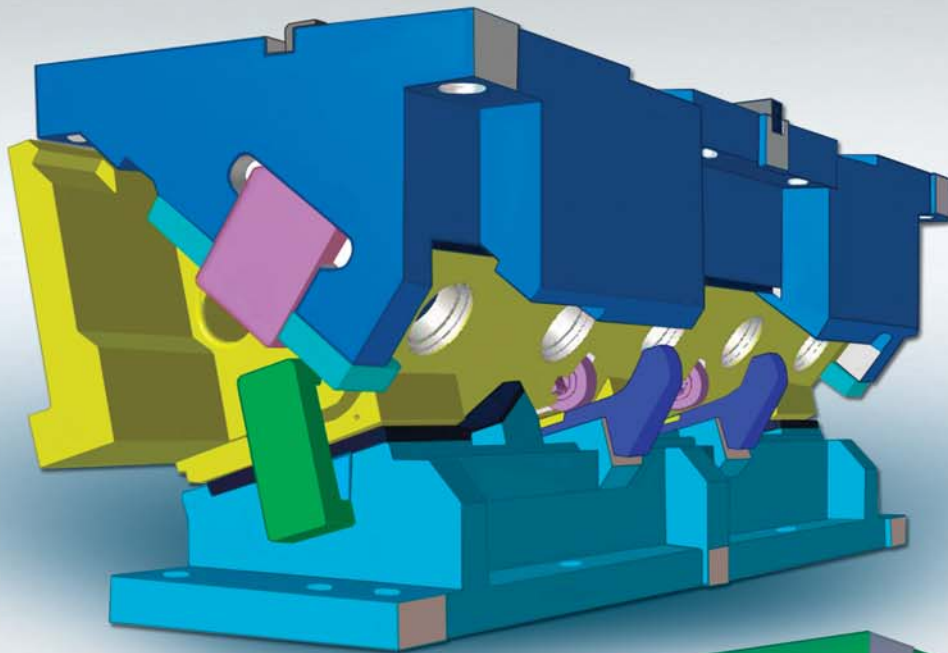

Service We Deliver and Quality You Can Depend On

IEM is a leading manufacturer of die sets and die component products supplied globally to the parts forming industry. Backed by years of tool and die experience, quality and innovation are some of the reasons why our name is respected throughout the world. We have taken the lead role in creating and bringing new products to customers and helping them find solutions that improve their operations. Based on the capabilities **IEM** offers, we can help you to meet the demands of quick deliveries, technical support, quality products and competitive prices. **IEM** and its broad distribution channels and direct sales personnel will assist you in any way to make your product a better and more profitable one.

Whether you purchase on-line or in person, you will receive the same reliable service **IEM** is known for. We understand the demanding schedules of die builders and production personnel and have developed efficient manufacturing processes to shorten product lead times as well as put inventory on our shelves so you can have it in your facility when you need it. Put the **IEM** network to work for you. We've got the service you've been looking for.

Included in our full line offering are both inch and metric size die sets and die components that are designed to numerous die standards including ISO, NAAMS, JIS and many large automotive and appliance manufacturers' standards. The complete product offering includes:

- Ball bearing and friction style die sets including custom and catalog sets
- Machined plate
- Guide posts & bushings
- ISO and JIS Die springs
- In-die tapping units for both mechanical and hydraulic presses
- Formathane[®] Urethane springs, strippers, sheets, bars, rods and die cover film
- Diemakers' supplies such as pry bars, dowel pins, hoist rings, clamps and fasteners
- Standard and self-lubricating wear product including wear plate, wear strips, gibs, keeper plates and guide blocks
- Cam units, including Mini[™], Aerial and Die Mount styles
- Accubend[™] Rotary Benders
- Standard and Ball lock punches and retainers
- Air presses
- Pad retainers
- Nitrogen gas springs



CONTENTS

	PAGE NUMBER
Product Information	2
Heavy Duty Wide Aerial Cams	
500-600 mm	4
700-800 mm	6
900-1000 mm	8
1100-1200 mm	10
Heavy Duty Wide Die Mount Cams	
500-600 mm	12
700-800 mm	14
900-1000 mm	16
1100-1200 mm	18
Calculation of Load and Stroke	20

Product Information

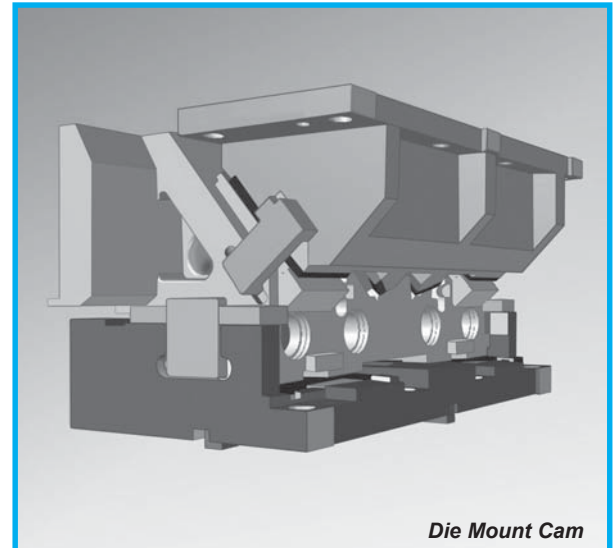
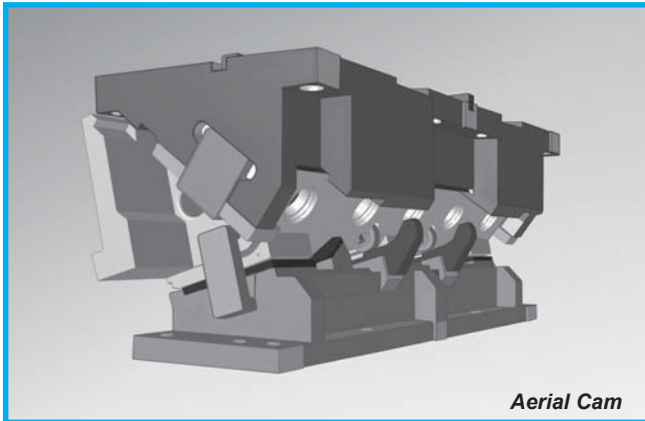

Product Features

- ◆ Cam angles are in 5° increments – Aerial Cams from 0° to 60°; Die Mount Cams from 0° to 20°.
- ◆ The cams will be categorized by mounting face width, which determines the shut height and overall width. (See the chart on the following page.)
- ◆ All cam units are heavy duty high volume and completely hard metric.
- ◆ All wear surfaces will be double plated aluminum bronze with graphite plugs running against plain hardened steel.
- ◆ Wear plates are backed up in the direction of thrust.
- ◆ Wear plates conform to VDI specifications for 12mm thick plates.
- ◆ Aerial Cams are guided by drivers with “V” guides.
- ◆ Cams can be ordered with coil springs or nitrogen springs.

Product Information

	MOUNTING SURFACE WIDTH	SHUT HEIGHT	MAXIMUM TOOLING WT. INCLUDING ADAPTER PLATE		TOOLING OVERHANG "L" MAX.	SPRING RETURN FORCE FINAL LOAD IN (N)		RATED OUTPUT	
			kg. MAX	LBS. MAX.		COIL (CS)	NITROGEN (NS)	kN	Tonf
AERIAL	500 / 600	385	150	330	200	7884	20700	372	37.9
	700 / 800	385	200	440	200	11826	20700	496	50.6
	900 / 1000	385	250	550	200	14853	31100	620	63
	1100 / 1200	385	250	550	200	14853	51825	930	94.8
DIE MOUNT	500 / 600	385	150	330	200	7884	20700	325.5	33.2
	700 / 800	385	200	440	200	11826	20700	434	44.3
	900 / 1000	385	250	550	200	14853	31000	542.5	55.3
	1100 / 1200	385	250	550	200	14853	51825	744	75.9

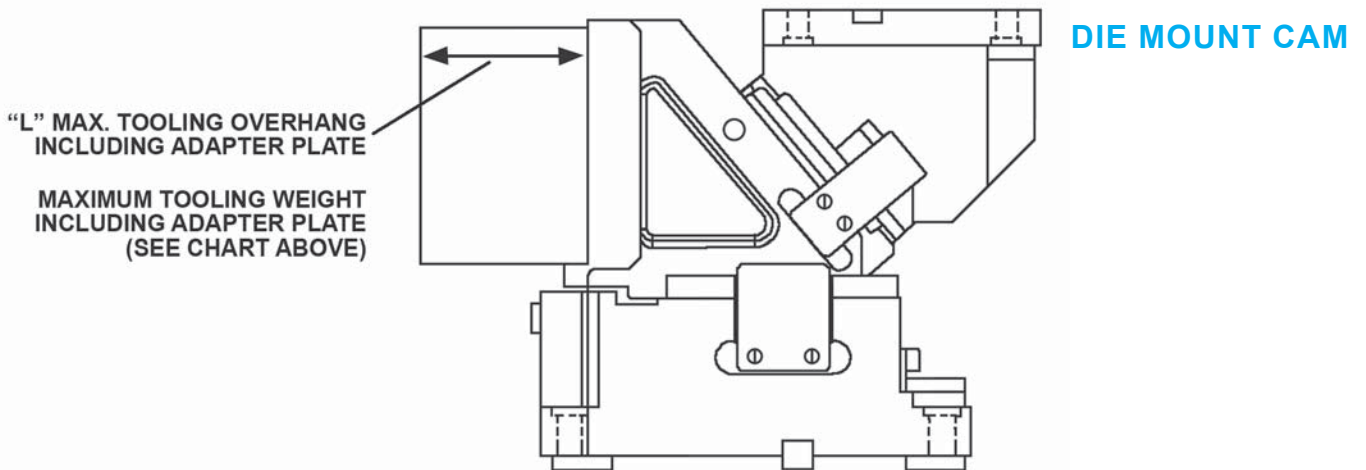
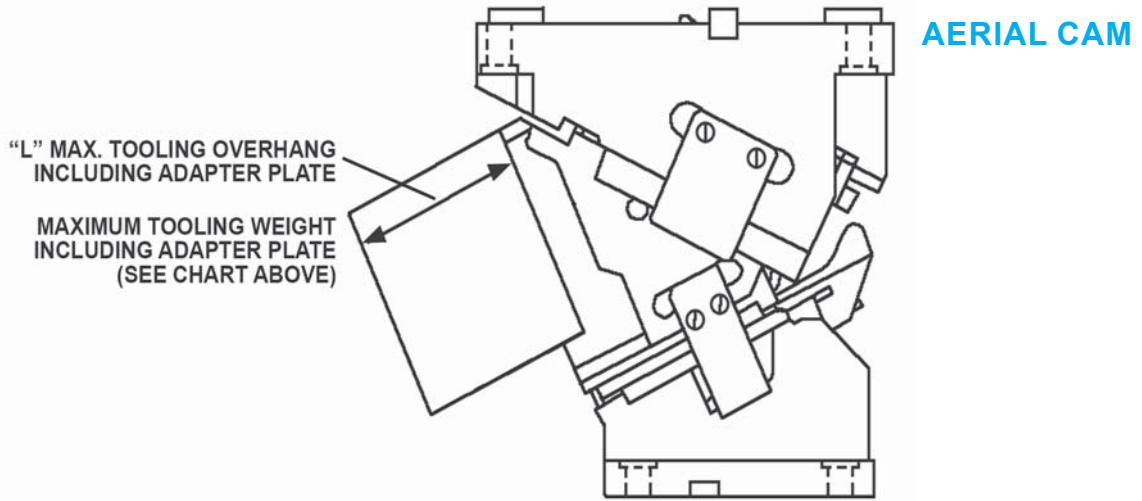

Heavy Duty Wide Aerial Cam – 500–600 mm

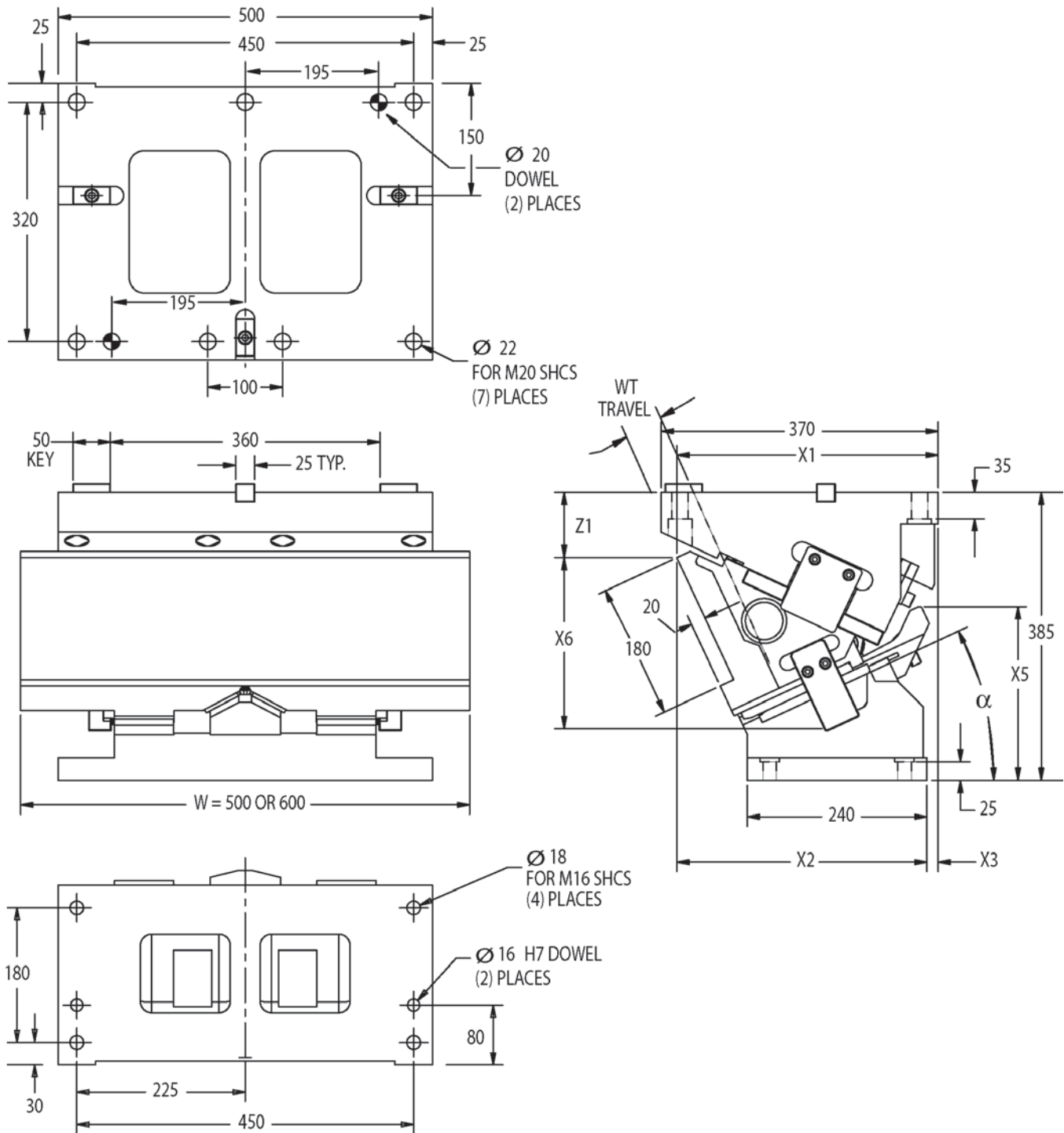

Ask Customer Service for design templates on our website or CD.
Picture not representative of all angles.

All dimensions are for reference only.
No tolerance is stated or implied.

Heavy Duty Wide Aerial Cam – 500–600 mm

MOUNTING FACE WIDTH 500 OR 600
 MOUNTING FACE HEIGHT 180
 OVERALL CAM WIDTH SEE PAGE 4
 SHUT HEIGHT 385

SLIDE STROKE 60.0
 WORK TRAVEL (WT) SEE CHART
 PRESS STROKE (PT) SEE CHART

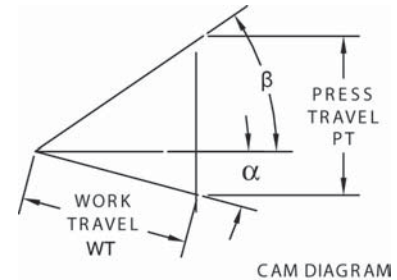

FASTENER SCHEDULE DOWELS SCREWS
 DRIVER 2-Ø16 4-M16
 BODY 2-Ø20 7-M20



CAM WIDTH 500 = W

PART NUMBER		kg	WT	PT	NOTE: FOR REST OF DIMENSIONS SEE CHART BELOW
WAC0500-00	0	299.6	38.6	46.0	
WAC0500-05	5	290.6	42.6	46.1	
WAC0500-10	10	281.9	46.7	46.7	
WAC0500-15	15	275.6	50.9	47.6	
WAC0500-20	20	272.4	55.3	48.9	
WAC0500-25	25	271.5	60.0	50.7	
WAC0500-30	30	277.4	65.1	53.1	
WAC0500-35	35	279.2	70.8	56.1	
WAC0500-40	40	280.6	77.1	60.0	
WAC0500-45	45	280.6	84.5	65.0	
WAC0500-50	50	286.0	93.3	71.0	
WAC0500-55	55	300.1	101.1	98.4	
WAC0500-60	60	291.9	118.2	112.8	

ORDERING EXAMPLE:

WAC0500-10 xx
 COIL SPRING (CS) 
 NITROGEN SPRING (NS) 

SPRING RETURN FORCE FINAL LOAD (Kg/lbs)		# OF SPRINGS WITH CAM	OPTIONAL SPRING POCKETS	RETURN FORCE PER SPRING
TYPE	FINAL LOAD			FINAL (Kg/lbs)
COIL	662 kg/1460 lb	2	NONE	331 kg/730 lb
NITROGEN	2212 kg/4878 lb	2	NONE	1106 kg/2439 lb

NOTES

- ◆ Nitrogen cylinders do not have a pre-load. Listed nitrogen ratings are at the end of their stroke.
- ◆ Exceeding the maximum tooling envelope will reduce cam performance and shorten the life of the cam.

CAM WIDTH 600 = W

PART NUMBER		kg	WT	PT	α	β	X1	X2	X3	X5	X6	Z1	Z1+X6
WAC0600-00	0	306.0	38.6	46.0	0°	50°	323.1	219.1	104	128.5	295.0	57.0	352.0
WAC0600-05	5	297.0	42.6	46.1	5°	45°	329.7	249.7	80	151.0	286.5	59.0	345.5
WAC0600-10	10	288.3	46.7	46.7	10°	40°	336.1	271.1	65	171.7	275.8	62.2	338.0
WAC0600-15	15	282.0	50.9	47.6	15°	35°	342.7	292.7	50	192.6	262.9	67.1	330.0
WAC0600-20	20	278.8	55.3	48.9	20°	30°	347.4	312.4	35	213.9	248.1	74.7	322.8
WAC0600-25	25	277.9	60.0	50.7	25°	25°	349.2	334.2	15	231.7	231.4	87.2	318.6
WAC0600-30	30	283.8	65.1	53.1	30°	20°	351.0	351.0	0	238.1	213.0	104.3	317.3
WAC0600-35	35	285.6	70.8	56.1	35°	15°	353.7	368.7	-15	255.3	192.9	117.7	310.6
WAC0600-40	40	287.0	77.1	60.0	40°	10°	355.6	385.6	-30	269.7	171.3	130.2	301.5
WAC0600-45	45	287.0	84.5	65.0	45°	5°	355.4	393.4	-38	278.4	148.5	144.8	293.3
WAC0600-50	50	292.4	93.3	71.0	50°	0°	355.2	415.2	-60	220.7	124.5	161.8	286.3
WAC0600-55	55	306.9	101.1	98.4	55°	-5°	372.6	432.6	-60	223.4	107.8	188.2	296.0
WAC0600-60	60	298.7	118.2	112.8	60°	-10°	368.3	428.3	-60	202.7	82.5	202.1	284.6

Ask Customer Service for design templates on our website or CD.
 Picture not representative of all angles.

All dimensions are for reference only.
 No tolerance is stated or implied.

Heavy Duty Wide Aerial Cam – 700–800 mm

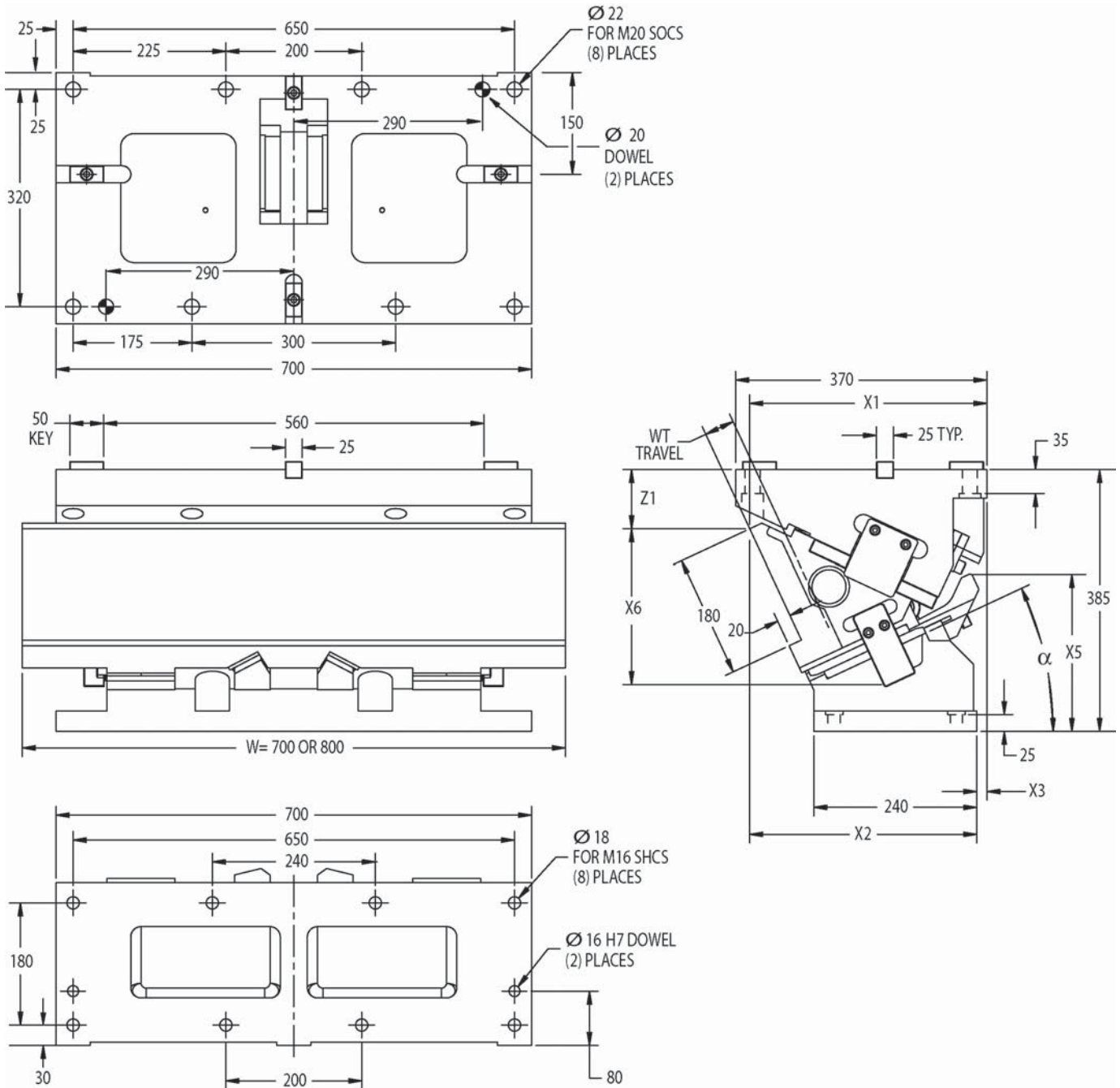

Ask Customer Service for design templates on our website or CD.
Picture not representative of all angles.

All dimensions are for reference only.
No tolerance is stated or implied.

Heavy Duty Wide Aerial Cam – 700–800 mm

MOUNTING FACE WIDTH 700 OR 800
 MOUNTING FACE HEIGHT 180
 OVERALL CAM WIDTH SEE PAGE 6
 SHUT HEIGHT 385

SLIDE STROKE 60.0
 WORK TRAVEL (WT) SEE CHART
 PRESS STROKE (PT) SEE CHART

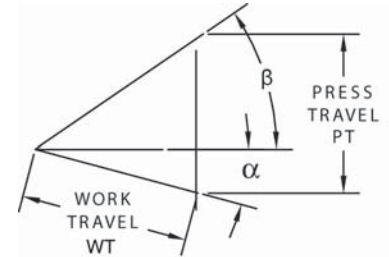

FASTENER SCHEDULE DOWELS SCREWS
 DRIVER 2-Ø16 8-M16
 BODY 2-Ø20 8-M20



CAM WIDTH 700 = W

PART NUMBER		kg	WT	PT	NOTE: FOR REST OF DIMENSIONS SEE CHART BELOW
WAC0700-00	0	405.7	38.6	46.0	
WAC0700-05	5	394.4	42.6	46.1	
WAC0700-10	10	385.8	46.7	46.7	
WAC0700-15	15	421.6	50.9	47.6	
WAC0700-20	20	371.1	55.3	48.9	
WAC0700-25	25	372.3	60.0	50.7	
WAC0700-30	30	379.7	65.1	53.1	
WAC0700-35	35	382.3	70.8	56.1	
WAC0700-40	40	384.1	77.1	60.0	
WAC0700-45	45	383.6	84.5	65.0	
WAC0700-50	50	394.9	93.3	71.0	
WAC0700-55	55	415.1	101.1	98.4	
WAC0700-60	60	407.6	118.2	112.8	

ORDERING EXAMPLE:

WAC0700-10 xx
 COIL SPRING (CS) 
 NITROGEN SPRING (NS) 

SPRING RETURN FORCE FINAL LOAD (Kg/lbs)		# OF SPRINGS WITH CAM	OPTIONAL SPRING POCKETS	RETURN FORCE PER SPRING
TYPE	FINAL LOAD			FINAL (Kg/lbs)
COIL	1324 kg/2920 lb	4	NONE	331 kg/730 lb
NITROGEN	2212 kg/4878 lb	2	2	1106 kg/2439 lb

NOTES

- ◆ Nitrogen cylinders do not have a pre-load. Listed nitrogen ratings are at the end of their stroke.
- ◆ Four spring pockets built into the cam, two nitrogen springs supplied with nitrogen spring configuration. Spring return calculated based on the standard spring quantity. Customer can add an additional spring for more return force.
- ◆ Exceeding the maximum tooling envelope will reduce cam performance and shorten the life of the cam.

CAM WIDTH 800 = W

PART NUMBER		kg	WT	PT	α	β	X1	X2	X3	X5	X6	Z1	Z1+X6
WAC0800-00	0	412.2	38.6	46.0	0°	50°	323.1	219.1	104	128.5	295.0	57.0	352.0
WAC0800-05	5	400.9	42.6	46.1	5°	45°	329.7	249.7	80	151.0	286.5	59.0	345.5
WAC0800-10	10	392.3	46.7	46.7	10°	40°	336.1	271.1	65	171.7	275.8	62.2	338.0
WAC0800-15	15	428.1	50.9	47.6	15°	35°	342.7	292.7	50	192.6	262.9	67.1	330.0
WAC0800-20	20	377.6	55.3	48.9	20°	30°	347.4	312.4	35	213.9	248.1	74.7	322.8
WAC0800-25	25	378.8	60.0	50.7	25°	25°	349.2	334.2	15	231.7	231.4	87.2	318.6
WAC0800-30	30	386.2	65.1	53.1	30°	20°	351.0	351.0	0	238.1	213.0	104.3	317.3
WAC0800-35	35	388.8	70.8	56.1	35°	15°	353.7	368.7	-15	255.3	192.9	117.7	310.6
WAC0800-40	40	390.6	77.1	60.0	40°	10°	355.6	385.6	-30	269.7	171.3	130.2	301.5
WAC0800-45	45	390.1	84.5	65.0	45°	5°	355.4	393.4	-38	278.4	148.5	144.8	293.3
WAC0800-50	50	401.4	93.3	71.0	50°	0°	355.2	415.2	-60	220.7	124.5	161.8	286.3
WAC0800-55	55	421.8	101.1	98.4	55°	-5°	372.6	432.6	-60	223.4	107.8	188.2	296.0
WAC0800-60	60	414.3	118.2	112.8	60°	-10°	368.3	428.3	-60	202.7	82.5	202.1	284.6

Ask Customer Service for design templates on our website or CD.
 Picture not representative of all angles.

All dimensions are for reference only.
 No tolerance is stated or implied.

Heavy Duty Wide Aerial Cam – 900–1000 mm

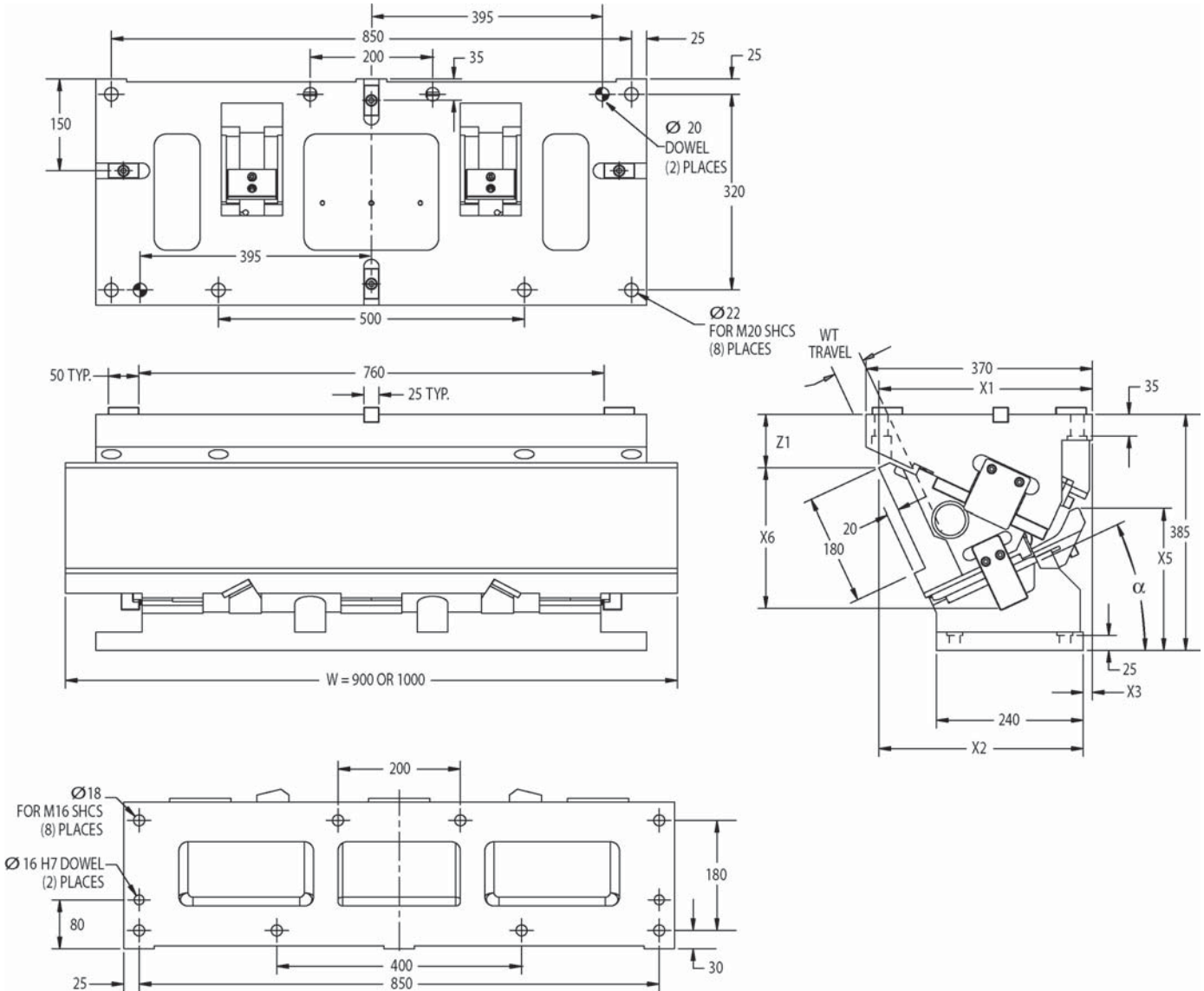

Ask Customer Service for design templates on our website or CD.
Picture not representative of all angles.

All dimensions are for reference only.
No tolerance is stated or implied.

Heavy Duty Wide Aerial Cam – 900–1000 mm

MOUNTING FACE WIDTH 900 OR 1000
MOUNTING FACE HEIGHT 180
OVERALL CAM WIDTH SEE PAGE 8
SHUT HEIGHT 385

SLIDE STROKE 60.0
WORK TRAVEL (WT) SEE CHART
PRESS STROKE (PT) SEE CHART

FASTENER SCHEDULE DOWELS SCREWS
DRIVER 2-Ø16 8-M16
BODY 2-Ø20 8-M20

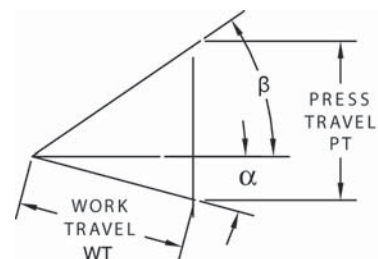



CAM DIAGRAM

CAM WIDTH 900 = W

PART NUMBER		kg	WT	PT	NOTE: FOR REST OF DIMENSIONS SEE CHART BELOW
WAC0900-00	0	518.5	38.6	46.0	
WAC0900-05	5	504.7	42.6	46.1	
WAC0900-10	10	491.8	46.7	46.7	
WAC0900-15	15	483.2	50.9	47.6	
WAC0900-20	20	478.6	55.3	48.9	
WAC0900-25	25	480.0	60.0	50.7	
WAC0900-30	30	489.3	65.1	53.1	
WAC0900-35	35	493.7	70.8	56.1	
WAC0900-40	40	495.1	77.1	60.0	
WAC0900-45	45	496.2	84.5	65.0	
WAC0900-50	50	510.2	93.3	71.0	
WAC0900-55	55	536.1	101.1	98.4	
WAC0900-60	60	523.0	118.2	112.8	

ORDERING EXAMPLE:

WAC0900-10 ^{xx}
COIL SPRING (CS) 
NITROGEN SPRING (NS) 

SPRING RETURN FORCE FINAL LOAD (Kg/lbs)		# OF SPRINGS WITH CAM	OPTIONAL SPRING POCKETS	RETURN FORCE PER SPRING
TYPE	FINAL LOAD			FINAL (Kg/lbs)
COIL	1655 kg/3650 lb	5	NONE	331 kg/730 lb
NITROGEN	3318 kg/7317 lb	3	2	1106 kg/2439 lb

NOTES

- ◆ Nitrogen cylinders do not have a pre-load. Listed nitrogen ratings are at the end of their stroke.
- ◆ Five spring pockets built into the cam, three nitrogen springs supplied with nitrogen spring configuration. Spring return calculated based on the standard spring quantity. Customer can add an additional spring for more return force.
- ◆ Exceeding the maximum tooling envelope will reduce cam performance and shorten the life of the cam.

CAM WIDTH 1000 = W

PART NUMBER		kg	WT	PT	α	β	X1	X2	X3	X5	X6	Z1	Z1+X6
WAC1000-00	0	525.3	38.6	46.0	0°	50°	323.1	219.1	104	128.5	295.0	57.0	352.0
WAC1000-05	5	511.5	42.6	46.1	5°	45°	329.7	249.7	80	151.0	286.5	59.0	345.5
WAC1000-10	10	498.6	46.7	46.7	10°	40°	336.1	271.1	65	171.7	275.8	62.2	338.0
WAC1000-15	15	490.0	50.9	47.6	15°	35°	342.7	292.7	50	192.6	262.9	67.1	330.0
WAC1000-20	20	485.4	55.3	48.9	20°	30°	347.4	312.4	35	213.9	248.1	74.7	322.8
WAC1000-25	25	486.8	60.0	50.7	25°	25°	349.2	334.2	15	231.7	231.4	87.2	318.6
WAC1000-30	30	496.1	65.1	53.1	30°	20°	351.0	351.0	0	238.1	213.0	104.3	317.3
WAC1000-35	35	500.5	70.8	56.1	35°	15°	353.7	368.7	-15	255.3	192.9	117.7	310.6
WAC1000-40	40	501.9	77.1	60.0	40°	10°	355.6	385.6	-30	269.7	171.3	130.2	301.5
WAC1000-45	45	503.0	84.5	65.0	45°	5°	355.4	393.4	-38	278.4	148.5	144.8	293.3
WAC1000-50	50	517.0	93.3	71.0	50°	0°	355.2	415.2	-60	220.7	124.5	161.8	286.3
WAC1000-55	55	542.8	101.1	98.4	55°	-5°	372.6	432.6	-60	223.4	107.8	188.2	296.0
WAC1000-60	60	529.7	118.2	112.8	60°	-10°	368.3	428.3	-60	202.7	82.5	202.1	284.6

Ask Customer Service for design templates on our website or CD.
Picture not representative of all angles.

All dimensions are for reference only.
No tolerance is stated or implied.

Heavy Duty Wide Aerial Cam – 1100–1200 mm

MOUNTING FACE WIDTH 1100 OR 1200
 MOUNTING FACE HEIGHT 180
 OVERALL CAM WIDTH SEE PAGE 10
 SHUT HEIGHT 385

SLIDE STROKE 60.0
 WORK TRAVEL (WT) SEE CHART
 PRESS STROKE (PT) SEE CHART

FASTENER SCHEDULE DOWELS SCREWS
 DRIVER 2-Ø16 8-M16
 BODY 2-Ø20 8-M20

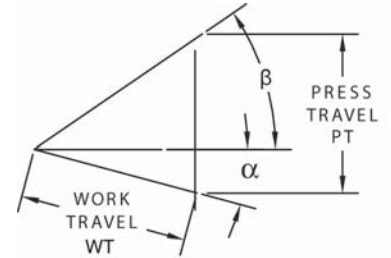



CAM DIAGRAM

CAM WIDTH 1100 = W

PART NUMBER		kg	WT	PT	NOTE: FOR REST OF DIMENSIONS SEE CHART BELOW
WAC1100-00	0	685.3	38.6	46.0	
WAC1100-05	5	669.8	42.6	46.1	
WAC1100-10	10	656.1	46.7	46.7	
WAC1100-15	15	644.8	50.9	47.6	
WAC1100-20	20	641.5	55.3	48.9	
WAC1100-25	25	644.9	60.0	50.7	
WAC1100-30	30	663.2	65.1	53.1	
WAC1100-35	35	662.0	70.8	56.1	
WAC1100-40	40	666.3	77.1	60.0	
WAC1100-45	45	666.7	84.5	65.0	
WAC1100-50	50	685.3	93.3	71.0	
WAC1100-55	55	718.7	101.1	98.4	
WAC1100-60	60	697.7	118.2	112.8	
WAC1100-65	65	727.0	141.4	133.4	

ORDERING EXAMPLE:

WAC01100-10^{xx}
 COIL SPRING (CS) 
 NITROGEN SPRING (NS) 

SPRING RETURN FORCE FINAL LOAD (Kg/lbs)		# OF SPRINGS WITH CAM	OPTIONAL SPRING POCKETS	RETURN FORCE PER SPRING
TYPE	FINAL LOAD			FINAL (Kg/lbs)
COIL	1655 kg/3650 lb	5	NONE	331 kg/730 lb
NITROGEN	3318 kg/7317 lb	3	2	1106 kg/2439 lb

NOTES

- ♦ Nitrogen cylinders do not have a pre-load. Listed nitrogen ratings are at the end of their stroke.
- ♦ Five spring pockets built into the cam, three nitrogen springs supplied with nitrogen spring configuration. Spring return calculated based on the standard spring quantity. Customer can add an additional spring for more return force.
- ♦ Exceeding the maximum tooling envelope will reduce cam performance and shorten the life of the cam.

CAM WIDTH 1200 = W

PART NUMBER		kg	WT	PT	α	β	X1	X2	X3	X5	X6	Z1	Z1+X6
WAC1200-00	0	691.5	38.6	46.0	0°	50°	323.1	219.1	104	133.2	295.0	57.0	352.0
WAC1200-05	5	676.0	42.6	46.1	5°	45°	329.7	249.7	80	154.1	286.5	59.0	345.5
WAC1200-10	10	662.3	46.7	46.7	10°	40°	336.1	271.1	65	169.3	275.8	62.2	338.0
WAC1200-15	15	651.0	50.9	47.6	15°	35°	342.7	292.7	50	190.4	260.0	67.1	327.1
WAC1200-20	20	647.7	55.3	48.9	20°	30°	347.4	312.4	35	208.7	245.3	74.7	320.0
WAC1200-25	25	651.1	60.0	50.7	25°	25°	349.2	334.2	15	222.1	228.7	87.2	315.9
WAC1200-30	30	669.4	65.1	53.1	30°	20°	351.0	351.0	0	236.7	210.4	104.3	314.7
WAC1200-35	35	668.2	70.8	56.1	35°	15°	353.7	368.7	-15	251.9	190.4	117.7	308.1
WAC1200-40	40	672.5	77.1	60.0	40°	10°	355.6	385.6	-30	270.1	169.0	130.2	299.2
WAC1200-45	45	672.9	84.5	65.0	45°	5°	355.4	393.4	-38	284.9	146.4	144.8	291.2
WAC1200-50	50	691.5	93.3	71.0	50°	0°	355.2	415.2	-60	198.6	122.6	161.8	284.4
WAC1200-55	55	725.0	101.1	98.4	55°	15°	372.6	432.6	-60	203.6	106.0	188.2	294.2
WAC1200-60	60	704.0	118.2	112.8	60°	10°	368.3	428.3	-60	185.4	81.0	202.1	283.1
WAC1200-65	65	733.3	141.4	133.4	65°	5°	361.8	451.8	-90	217.7	55.4	217.5	272.9

Ask Customer Service for design templates on our website or CD.
 Picture not representative of all angles.

All dimensions are for reference only.
 No tolerance is stated or implied.

Heavy Duty Wide Die Mount Cam – 500–600 mm

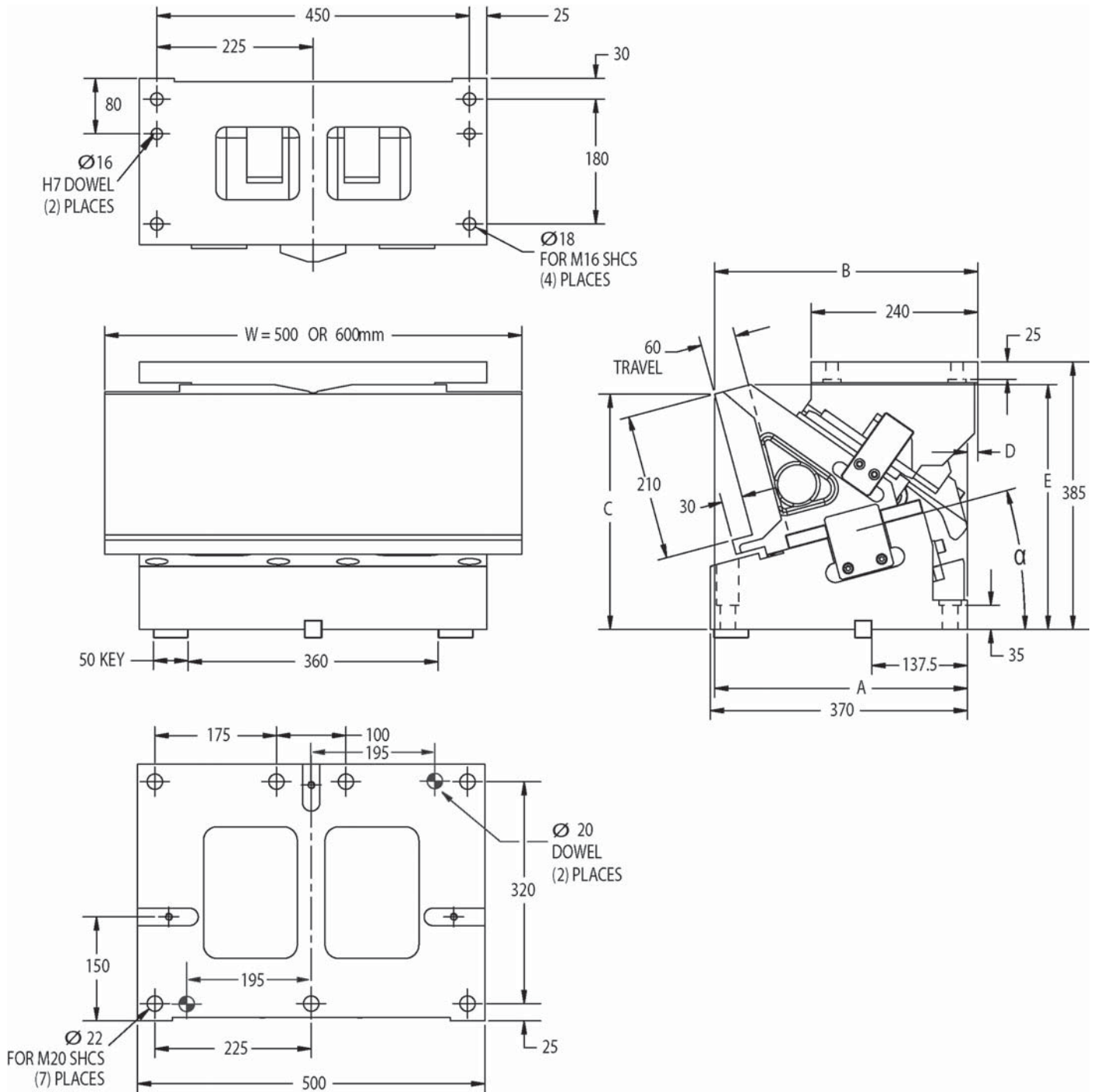

Ask Customer Service for design templates on our website or CD.
Picture not representative of all angles.

All dimensions are for reference only.
No tolerance is stated or implied.

Heavy Duty Wide Die Mount Cam – 500–600 mm



MOUNTING FACE WIDTH 500 OR 600
 MOUNTING FACE HEIGHT 210
 OVERALL CAM WIDTH SEE PAGE 12
 SHUT HEIGHT 385

SLIDE STROKE 60.0
 WORK TRAVEL (WT) 60.0
 PRESS STROKE (PT) SEE CHART

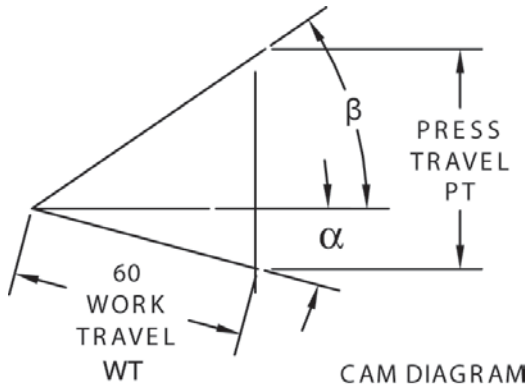
FASTENER SCHEDULE DOWELS SCREWS
 DRIVER 2-Ø16 4-M16
 BODY 2-Ø20 7-M20



ORDERING EXAMPLE:

WDM0500-10 xx
 COIL SPRING (CS) 
 NITROGEN SPRING (NS) 

SPRING RETURN FORCE FINAL LOAD (Kg/lbs)		# OF SPRINGS WITH CAM	OPTIONAL SPRING POCKETS	RETURN FORCE PER SPRING
TYPE	FINAL LOAD			FINAL (Kg/lbs)
COIL	662 kg/1460 lb	2	NONE	331 kg/730 lb
NITROGEN	2212 kg/4878 lb	2	NONE	1106 kg/2439 lb

NOTES

- ◆ Nitrogen cylinders do not have a pre-load. Listed nitrogen ratings are at the end of their stroke.
- ◆ Exceeding the maximum tooling envelope will reduce cam performance and shorten the life of the cam.

CAM WIDTH	PART NUMBER	α	β	PT	kg	A	B	C	D	E
500mm	WDM0500-00	0°	50°	71.5	333.2	330.00	390.00	375.00	60	375.00
	WDM0500-05	5°	45°	65.0	324.1	348.90	386.90	359.40	38	366.00
	WDM0500-10	10°	40°	60.0	315.5	367.80	397.80	344.50	30	357.30
	WDM0500-15	15°	35°	56.1	309.2	384.50	399.50	330.20	15	349.30
	WDM0500-20	20°	30°	53.0	306.0	400.20	400.20	313.30	0	338.50
600mm	WDM0600-00	0°	50°	71.5	340.5	330.00	390.00	375.00	60	375.00
	WDM0600-05	5°	45°	65.0	331.4	348.90	386.90	359.40	38	365.80
	WDM0600-10	10°	40°	60.0	322.8	367.80	397.80	344.50	30	357.30
	WDM0600-15	15°	35°	56.1	316.5	384.50	399.50	330.20	15	349.30
	WDM0600-20	20°	30°	53.0	313.3	400.20	400.20	313.30	0	338.50

Heavy Duty Wide Die Mount Cam – 700–800 mm

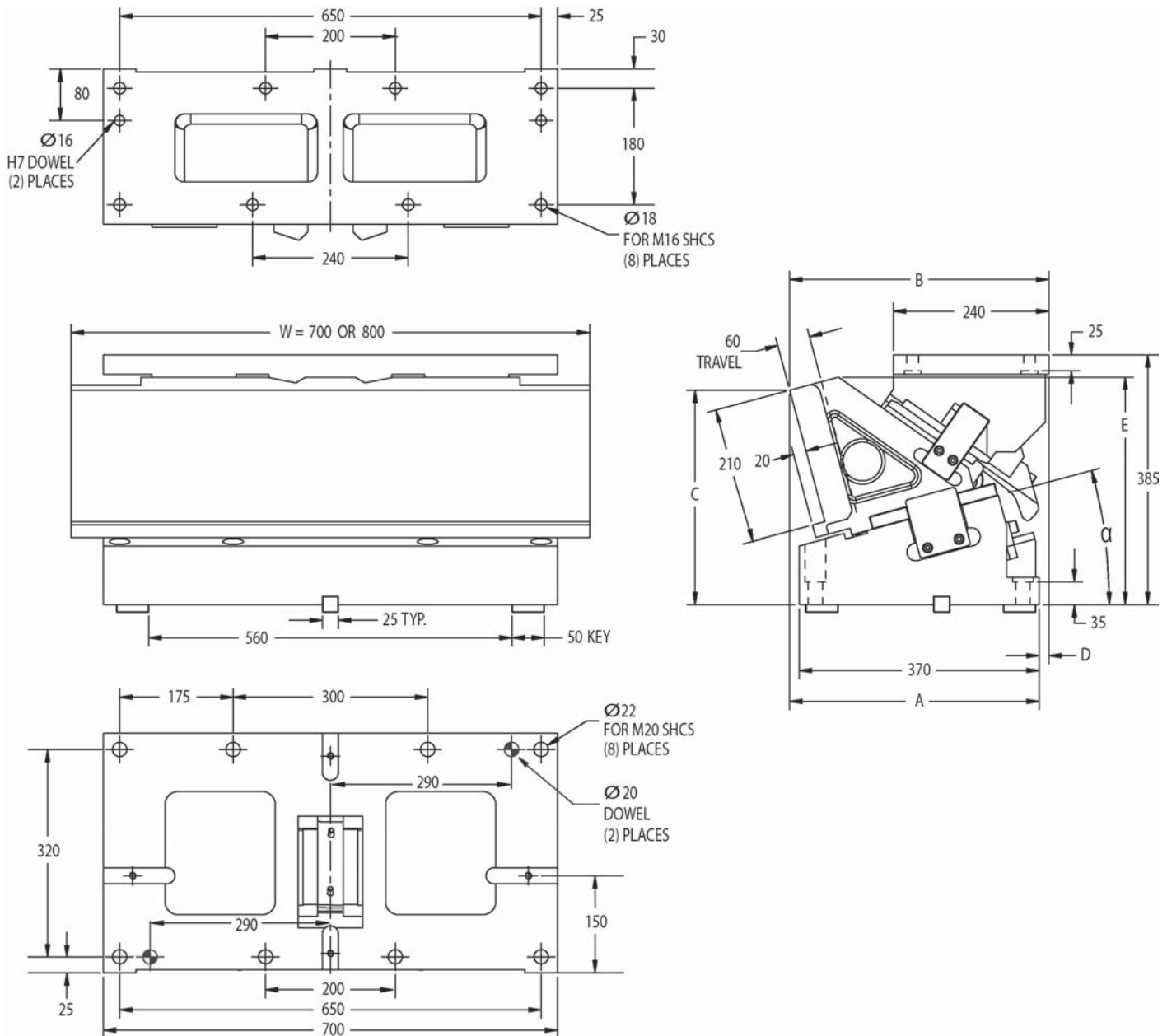

Ask Customer Service for design templates on our website or CD.
Picture not representative of all angles.

All dimensions are for reference only.
No tolerance is stated or implied.

Heavy Duty Wide Die Mount Cam – 700–800 mm



MOUNTING FACE WIDTH 700 OR 800
 MOUNTING FACE HEIGHT 210
 OVERALL CAM WIDTH SEE PAGE 14
 SHUT HEIGHT 385

SLIDE STROKE 60.0
 WORK TRAVEL (WT) 60
 PRESS STROKE (PT) SEE CHART

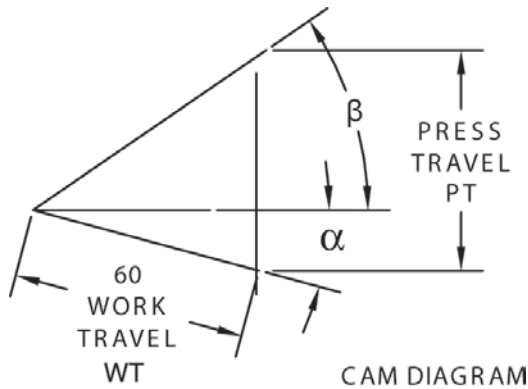
FASTENER SCHEDULE DOWELS SCREWS
 DRIVER 2-Ø16 8-M16
 BODY 2-Ø20 8-M20



ORDERING EXAMPLE:

WDM0700-10 xx
 COIL SPRING (CS) 
 NITROGEN SPRING (NS) 

SPRING RETURN FORCE FINAL LOAD (Kg/lbs)		# OF SPRINGS WITH CAM	OPTIONAL SPRING POCKETS	RETURN FORCE PER SPRING
TYPE	FINAL LOAD			FINAL (Kg/lbs)
COIL	1324 kg/1460 lb	4	NONE	331 kg/730 lb
NITROGEN	2212 kg/4878 lb	2	2	1106 kg/2439 lb

NOTES

- ◆ Nitrogen cylinders do not have a pre-load. Listed nitrogen ratings are at the end of their stroke.
- ◆ Four spring pockets built into the cam, two nitrogen springs supplied with nitrogen spring configuration. Spring return calculated based on the standard spring quantity. Customer can add an additional spring for more return force.
- ◆ Exceeding the maximum tooling envelope will reduce cam performance and shorten the life of the cam.

CAM WIDTH	PART NUMBER	α	β	PT	kg	A	B	C	D	E
700mm	WDM0700-00	0°	50°	71.5	387.2	330.00	390.00	375.00	60	375.00
	WDM0700-05	5°	45°	65.0	378.1	348.90	386.90	359.40	38	366.00
	WDM0700-10	10°	40°	60.0	369.5	367.80	397.80	344.50	30	357.30
	WDM0700-15	15°	35°	56.1	309.2	384.50	399.50	330.20	15	349.30
	WDM0700-20	20°	30°	53.0	360.0	400.20	400.20	313.30	0	338.50
800mm	WDM0800-00	0°	50°	71.5	444.5	330.00	390.00	375.00	60	375.00
	WDM0800-05	5°	45°	65.0	381.4	348.90	386.90	359.40	38	365.80
	WDM0800-10	10°	40°	60.0	372.8	367.80	397.80	344.50	30	357.30
	WDM0800-15	15°	35°	56.1	366.5	384.50	399.50	330.20	15	349.30
	WDM0800-20	20°	30°	53.0	363.3	400.20	400.20	313.30	0	338.50

Heavy Duty Wide Die Mount Cam – 900–1000 mm

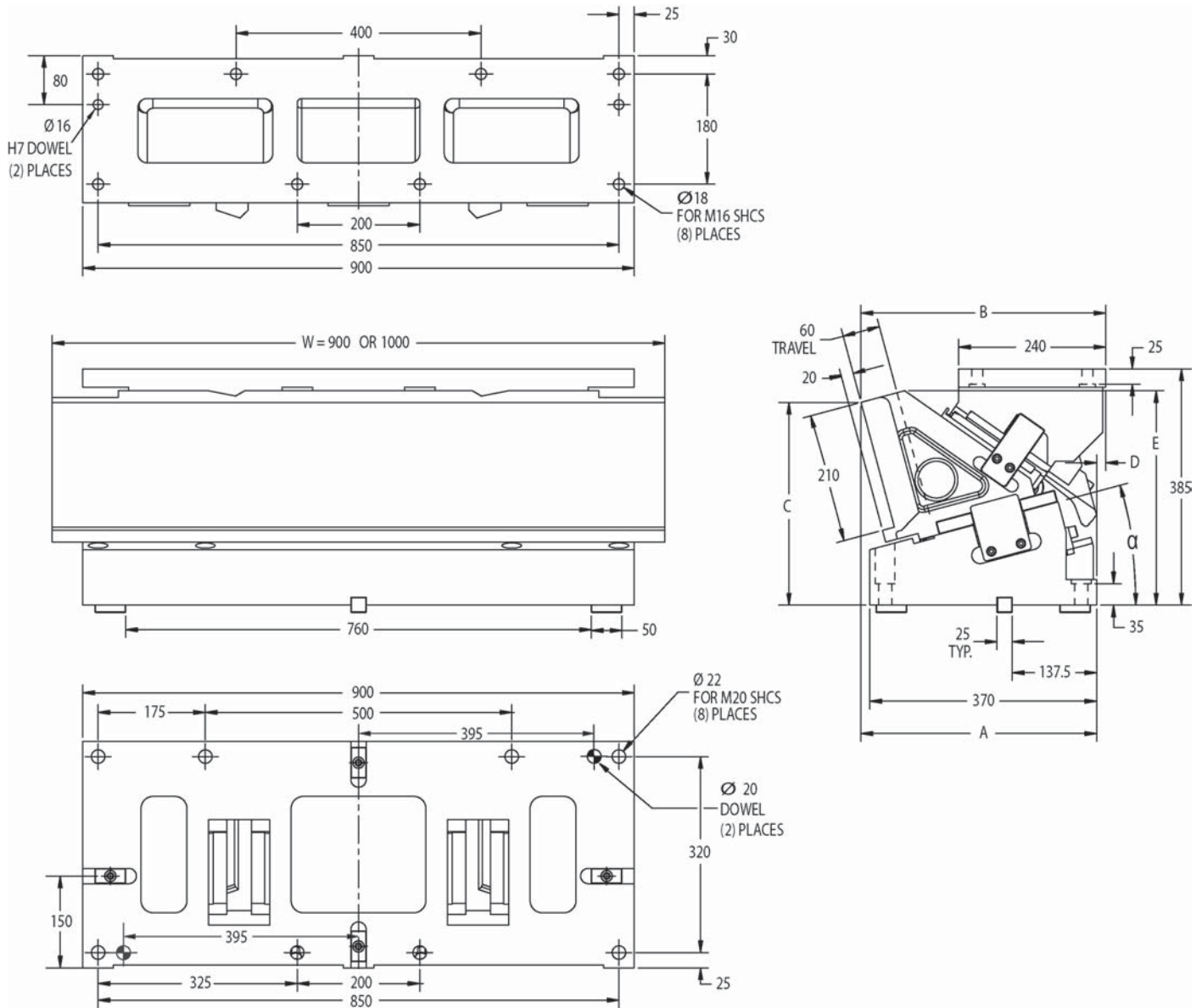

Ask Customer Service for design templates on our website or CD.
Picture not representative of all angles.

All dimensions are for reference only.
No tolerance is stated or implied.

Heavy Duty Wide Die Mount Cam – 900–1000 mm



MOUNTING FACE WIDTH 900 OR 1000
 MOUNTING FACE HEIGHT 210
 OVERALL CAM WIDTH SEE PAGE 16
 SHUT HEIGHT 385

SLIDE STROKE 60.0
 WORK TRAVEL (WT) 60
 PRESS STROKE (PT) SEE CHART

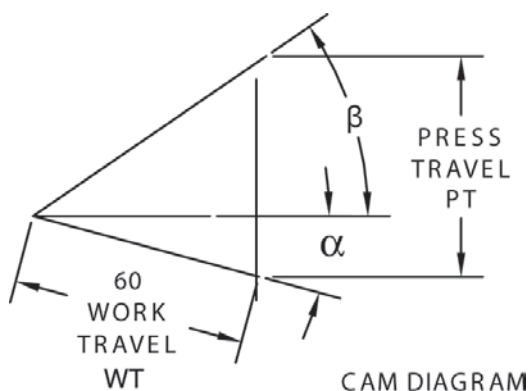
FASTENER SCHEDULE DOWELS SCREWS
 DRIVER 2-Ø16 8-M16
 BODY 2-Ø20 8-M20



ORDERING EXAMPLE:

WDM0900-10 xx
 COIL SPRING (CS) 
 NITROGEN SPRING (NS) 

SPRING RETURN FORCE FINAL LOAD (Kg/lbs)		# OF SPRINGS WITH CAM	OPTIONAL SPRING POCKETS	RETURN FORCE PER SPRING
TYPE	FINAL LOAD			FINAL (Kg/lbs)
COIL	1655 kg/3650 lb	5	NONE	331 kg/730 lb
NITROGEN	3318 kg/7317 lb	3	2	1106 kg/2439 lb

NOTES

- ◆ Nitrogen cylinders do not have a pre-load. Listed nitrogen ratings are at the end of their stroke.
- ◆ Five spring pockets built into the cam, three nitrogen springs supplied with nitrogen spring configuration. Spring return calculated based on the standard spring quantity. Customer can add an additional spring for more return force.
- ◆ Exceeding the maximum tooling envelope will reduce cam performance and shorten the life of the cam.

CAM WIDTH	PART NUMBER	α	β	PT	kg	A	B	C	D	E
900mm	WDM0900-00	0°	50°	71.5	573.0	330.00	390.00	375.00	60	375.00
	WDM0900-05	5°	45°	65.0	560.0	348.90	386.90	359.40	38	366.00
	WDM0900-10	10°	40°	60.0	559.0	367.80	397.80	344.50	30	357.30
	WDM0900-15	15°	35°	56.1	556.0	384.50	399.50	330.20	15	349.30
	WDM0900-20	20°	30°	53.0	552.0	400.20	400.20	313.30	0	338.50
1000mm	WDM1000-00	0°	50°	71.5	582.0	330.00	390.00	375.00	60	375.00
	WDM1000-05	5°	45°	65.0	569.0	348.90	386.90	359.40	38	365.80
	WDM1000-10	10°	40°	60.0	568.0	367.80	397.80	344.50	30	357.30
	WDM1000-15	15°	35°	56.1	565.0	384.50	399.50	330.20	15	349.30
	WDM1000-20	20°	30°	53.0	561.0	400.20	400.20	313.30	0	338.50

Heavy Duty Wide Die Mount Cam – 1100–1200 mm

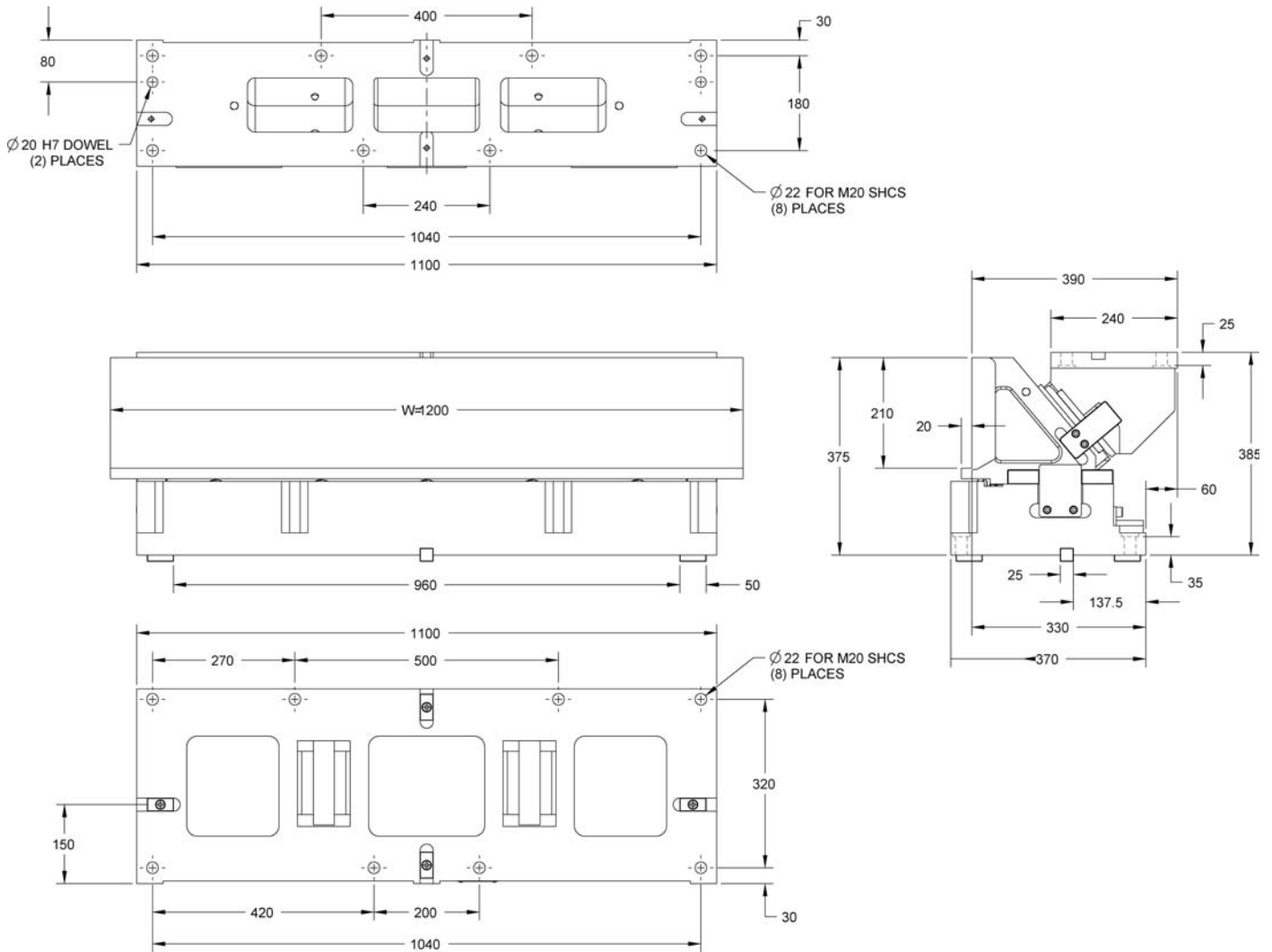

Ask Customer Service for design templates on our website or CD.
Picture not representative of all angles.

All dimensions are for reference only.
No tolerance is stated or implied.

Heavy Duty Wide Die Mount Cam – 1100–1200 mm



MOUNTING FACE WIDTH 1100 OR 1200
 MOUNTING FACE HEIGHT 210
 OVERALL CAM WIDTH SEE PAGE 18
 SHUT HEIGHT 385

SLIDE STROKE 60.0
 WORK TRAVEL (WT) 60
 PRESS STROKE (PT) SEE CHART

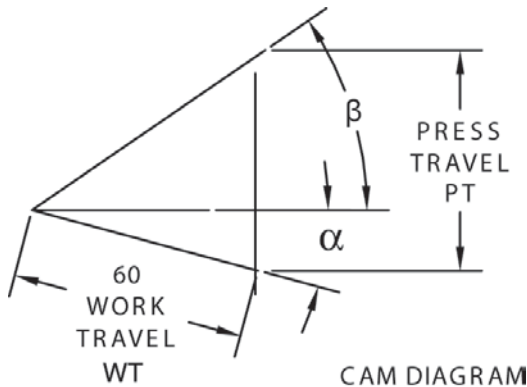
FASTENER SCHEDULE DOWELS SCREWS
 DRIVER 2-Ø20 H7 8-M20
 BODY NONE 8-M20



ORDERING EXAMPLE:

WDM1100-10 xx
 COIL SPRING (CS) 
 NITROGEN SPRING (NS) 

SPRING RETURN FORCE FINAL LOAD (Kg/lbs)		# OF SPRINGS WITH CAM	OPTIONAL SPRING POCKETS	RETURN FORCE PER SPRING
TYPE	FINAL LOAD			FINAL (Kg/lbs)
COIL	1655 kg/3650 lb	5	NONE	331 kg/730 lb
NITROGEN	3318 kg/7317 lb	3	2	1106 kg/2439 lb

NOTES

- ◆ Nitrogen cylinders do not have a pre-load. Listed nitrogen ratings are at the end of their stroke.
- ◆ Five spring pockets built into the cam, three nitrogen springs supplied with nitrogen spring configuration. Spring return calculated based on the standard spring quantity. Customer can add an additional spring for more return force.
- ◆ Exceeding the maximum tooling envelope will reduce cam performance and shorten the life of the cam.

CAM WIDTH	PART NUMBER	α	β	PT	kg	A	B	C	D	E
1100	WDM1100-00CS	0	50	71.5	736	330.0	390.0	375.0	60.0	375.0
	WDM1100-05CS	5	45	65	717.3	348.9	386.9	359.4	38.0	366.2
	WDM1100-10CS	10	40	60	716.6	367.8	397.8	344.5	30.0	357.3
	WDM1100-15CS	15	35	56.1	726.5	384.5	399.5	330.2	15.0	349.3
	WDM1100-20CS	20	30	53.1	705.8	400.2	400.2	313.3	0.0	339.8
1200	WDM1200-00CS	0	50	71.5	743.4	330.0	390.0	375.0	60.0	375.0
	WDM1200-05CS	5	45	65	724.7	348.9	386.9	359.4	38.0	366.2
	WDM1200-10CS	10	40	60	724	367.8	397.8	344.5	30.0	357.3
	WDM1200-15CS	15	35	56.1	733.9	384.5	399.5	330.2	15.0	349.3
	WDM1200-20CS	20	30	53.1	713.2	400.2	400.2	313.3	0.0	339.8

Ask Customer Service for design templates on our website or CD.
 Picture not representative of all angles.

All dimensions are for reference only.
 No tolerance is stated or implied.

Calculation of Load and Stroke

- Θ₁ DRIVER INCLINATION ANGLE
- Θ₂ WORK ANGLE
- F FORCE REQUIRED (PIERCING/TRIMMING/FLANGING FORCE + PAD FORCE + SPRING RETURN FORCE)
- P PRESS FORCE
- V LOAD ON SLIDE SURFACE AND DRIVER
- Q LOAD ON SLIDE SURFACE AND BODY
- S WORKING STROKE
- S₁ SPRING STROKE (SLIDE TRAVEL)
- L PRESS STROKE

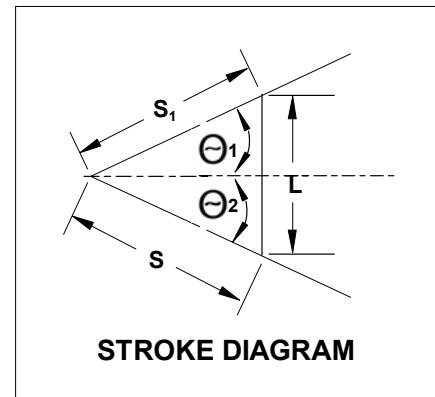
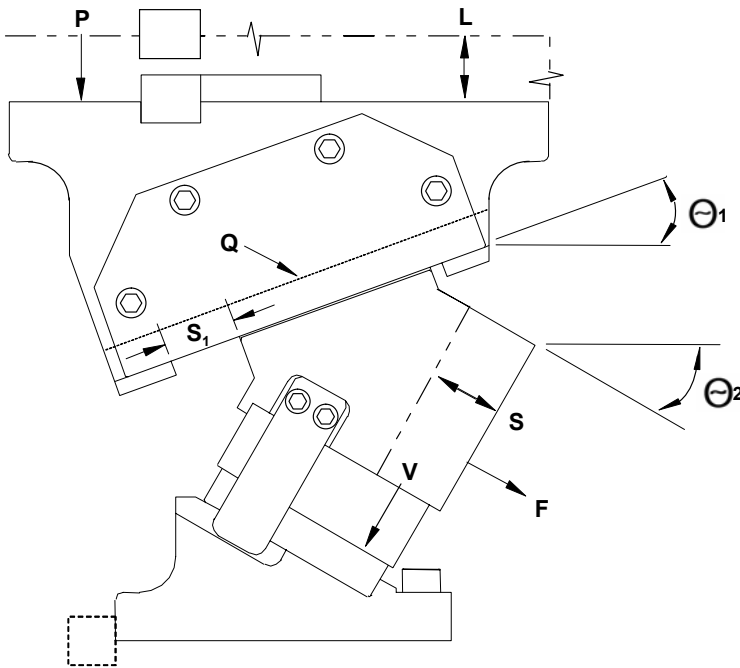

$P = F \times \frac{\cos \Theta_1}{\sin (\Theta_1 + \Theta_2)}$	$L = S \times \frac{\sin (\Theta_1 + \Theta_2)}{\cos \Theta_1}$
$Q = F \times \frac{1}{\sin (\Theta_1 + \Theta_2)}$	$S_1 = S \times \frac{\cos \Theta_2}{\cos \Theta_1}$
$V = F \times \frac{1}{\tan (\Theta_1 + \Theta_2)}$	$S = S \times \frac{\cos \Theta_1}{\cos \Theta_2}$

The IEM Value Proposition

- I. **IEM** is recognized as the leader in manufacturing quality die sets and related products to the global parts forming industry. Our reputation has been built by satisfying customer needs, and we are very strong in the automotive and appliance industries.
- II. **IEM** offers outstanding delivery on a consistent basis. Choosing us as a supplier means that our customers have a competitive advantage in delivering their products to the market.
- III. **IEM** has complex machining capabilities on die sets at several strategically located facilities. Locations throughout the USA means lower shipping costs and allowing **IEM** to machine complex die sets means the customer's machining centers have additional capacity.
- IV. **IEM's** vast breadth of products assures innovative solutions. We strive to address customer problems by utilizing our research and development department as well as other technical professionals.
- V. **IEM** has a technically trained sales force and distributor channels with engineering support. Sales, marketing and engineering professionals are available to support our product lines.

- **Competitive Prices**
- **Reliability and Performance**

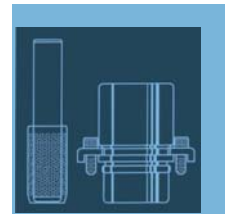
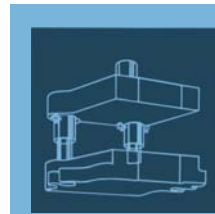

**...A LEADING MANUFACTURER
AND INNOVATOR OF DIE SETS
AND DIE COMPONENTS
SUPPLIED GLOBALLY TO THE
METAL FORMING INDUSTRY...**

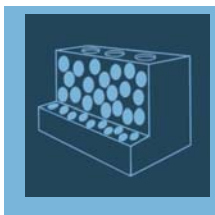
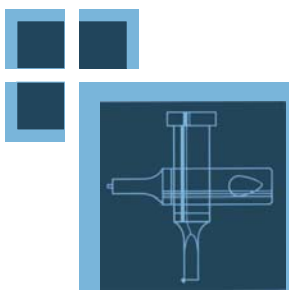

- **High Quality Design & Construction**
- **Outstanding Service & Support**

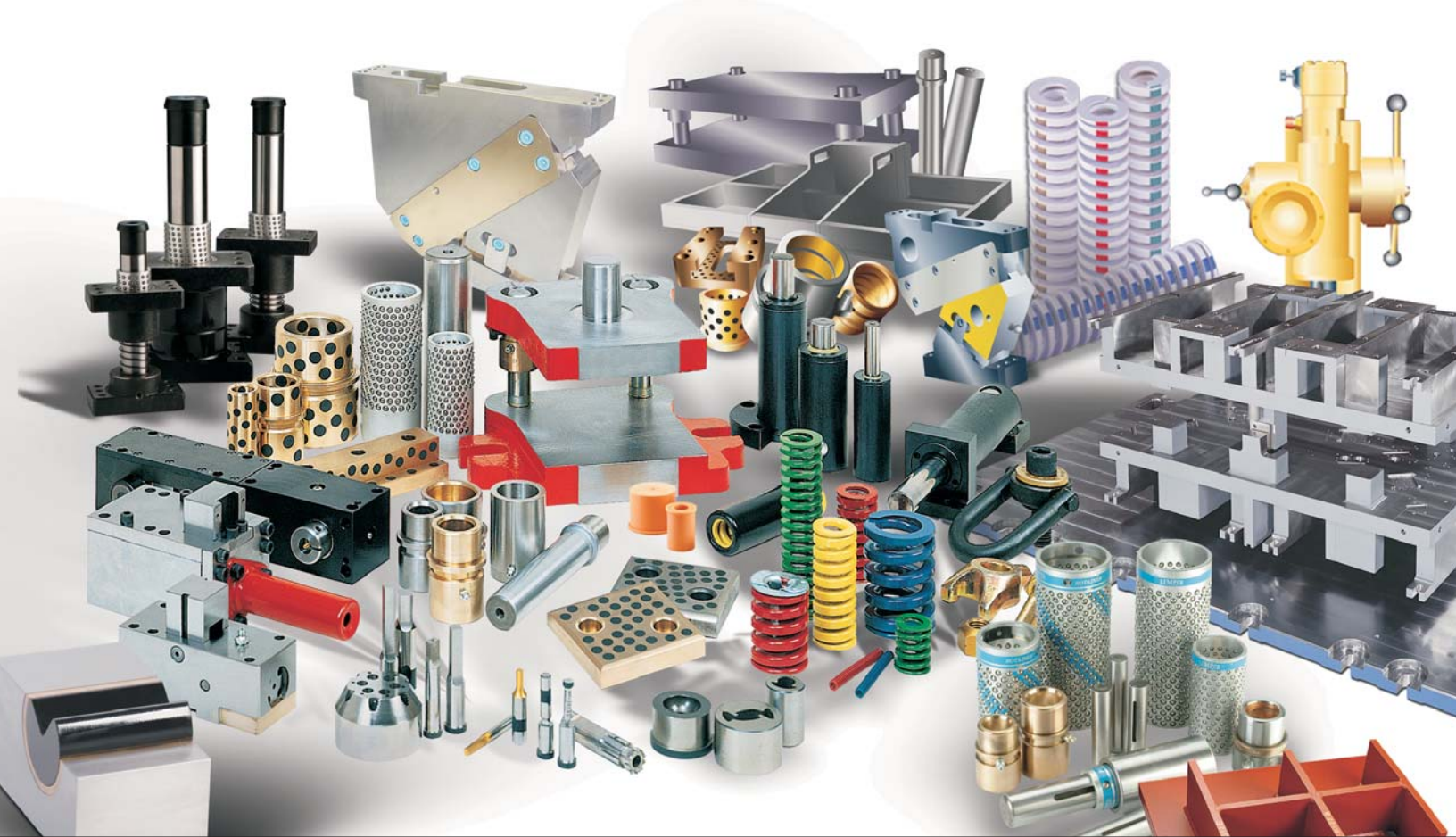

AERIAL & DIE MOUNT WIDE CAMS CATALOG



Distributed by:

www.danly.com
info@anchordanly.com

WITHIN THE USA & CANADA
CALL: 800-243-2659
FAX: 800-833-2659

OUTSIDE THE USA & CANADA
CALL: 248-489-7816
FAX: 248-553-6842

